

THIS DRAWING IS UNPUBLISHED. RELEASED FOR PUBLICATION , 19 .
 © COPYRIGHT 19 BY AMP INCORPORATED. ALL INTERNATIONAL RIGHTS RESERVED.

AMP PART NO	MATERIAL	PKG TYPE	QTY
8-36923-3	M/F 8-36923-0	BOX	25
8-36923-5	M/F 8-36923-0	BAG	5

LOC	DIST	P	F	ZONE	LTR	DESCRIPTION	DATE	APPD
G	14				M	REVISED PER 0L20-0148-96	10DEC96	OKS MJS

METRIC
 DIMENSIONS LISTED IN mm [INCHES]

AMP WIRE RANGE	UL E13288 Listed
2/0 AWG SOLID OR STRANDED	2/0 AWG STRANDED
SR LR7189 Certified	MILITARY P/N AND CLASS
2/0 AWG SOLID OR STRANDED	NOT APPLICABLE

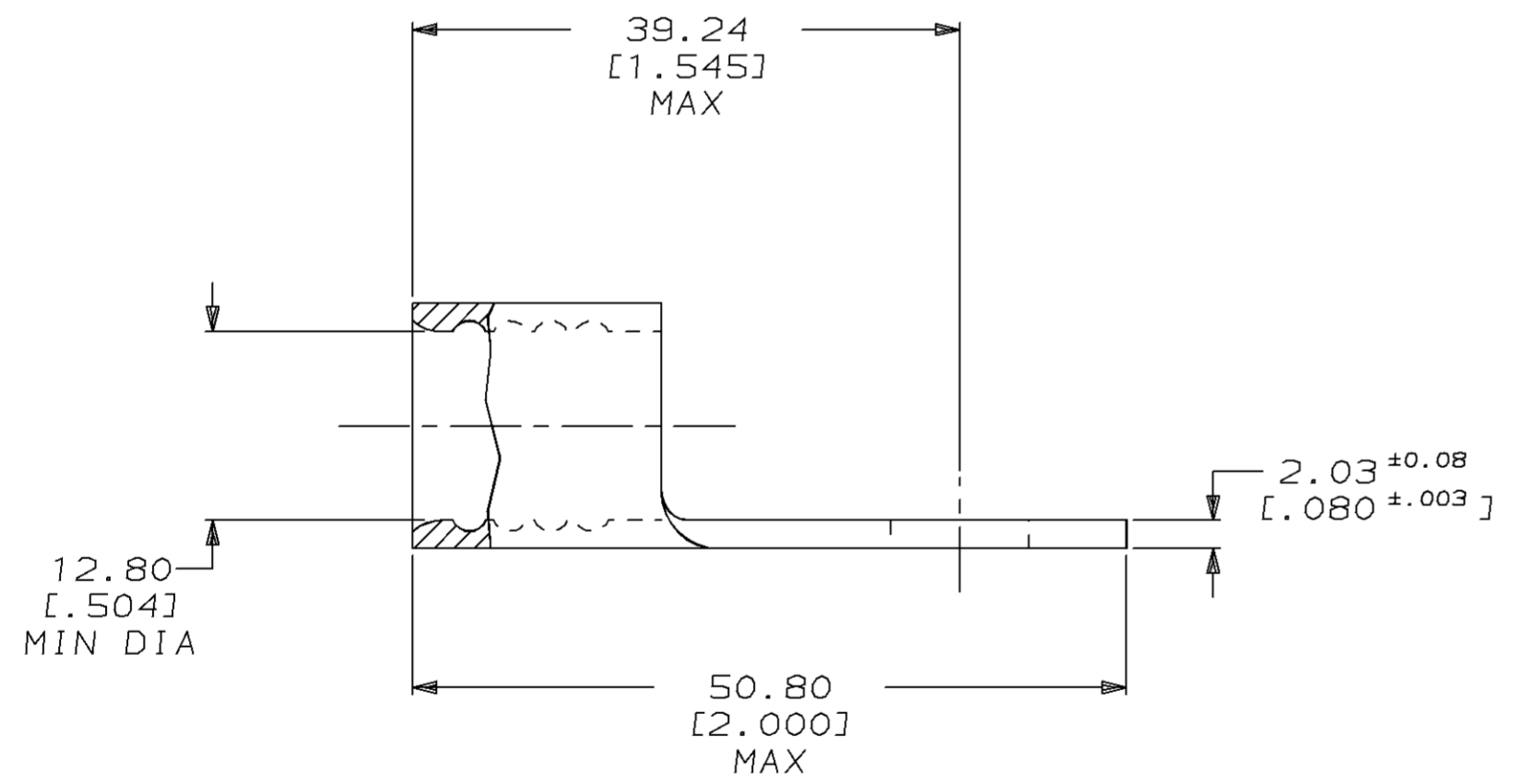
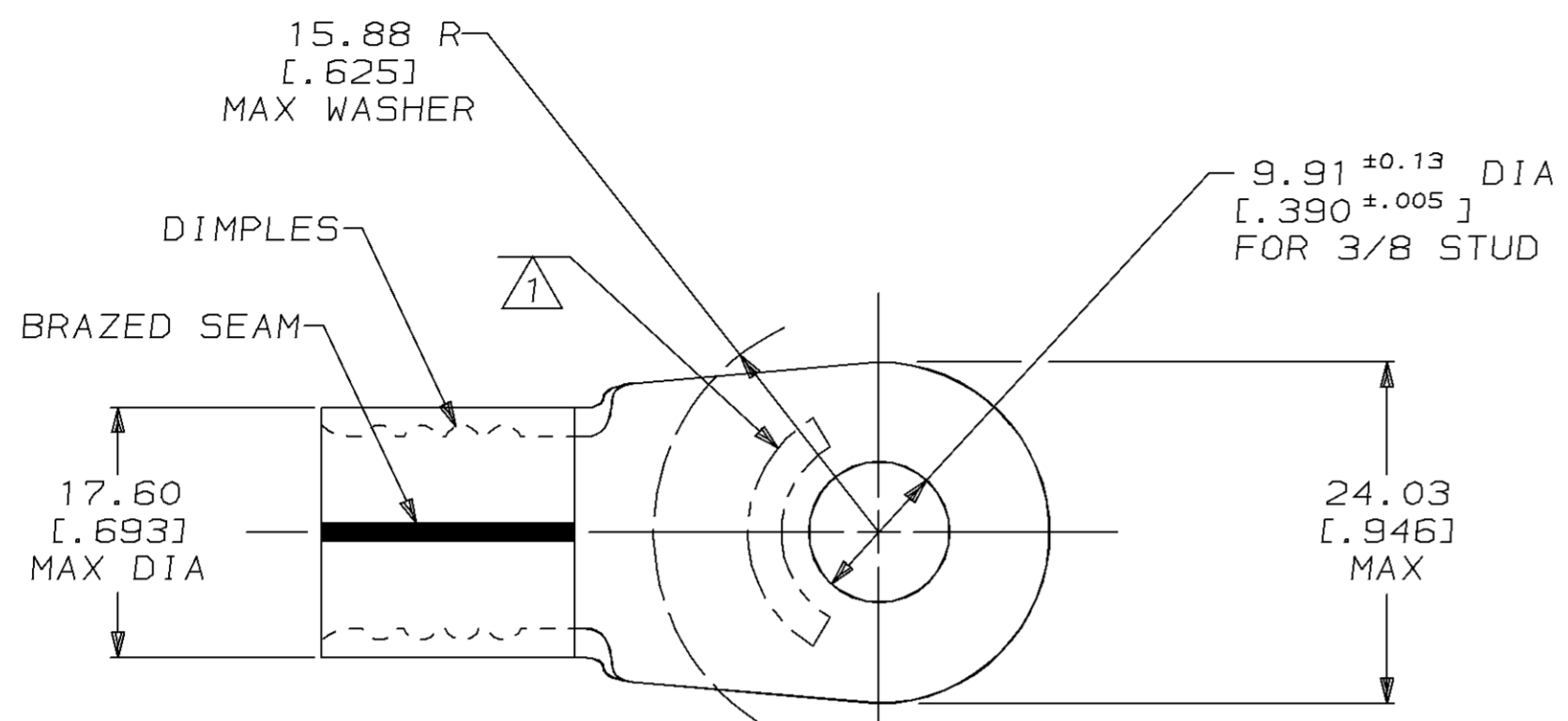

- ① STAMP AMP 2/0W* APPROX AS SHOWN
- ② TIN PL 0.00254 [.000100] MIN THK PER MIL-T-10727
- ③ NICKEL PL 0.00076 [.000030] MIN THK PER QQ-N-290

OBSOLETE	FINISH	PART NO
③		2-36923-4
②		36923

AMP INCORPORATED
CUSTOMER SERVICE SYSTEMS

FOR ADDITIONAL PRODUCT INFORMATION OR COPIES OF DRAWINGS AND TECHNICAL DOCUMENTS	PRODUCT INFORMATION CENTER 1-800-522-6752
FOR APPLICATION TOOLING INFORMATION	TOOLING ASSISTANCE CENTER 1-800-722-1111
FOR ORDER ENTRY	1-800-526-5142

MAX RECOMMENDED OPERATING TEMPERATURE:
 170°C MAX

VOLTAGE RATING:
 NOT APPLICABLE

WIRE CROSS SECTIONAL AREA RANGE:
 60.6-76.3mm² [119,500-150,500] CIR MILS
 SOLID OR STRANDED

THIS DRAWING IS A CONTROLLED DOCUMENT FOR AMP INCORPORATED. IT IS SUBJECT TO CHANGE AND THE CONTROLLING ENGINEERING ORGANIZATION SHOULD BE CONTACTED FOR THE LATEST REVISION.

DO NOT SCALE PRINT. UNLESS SPECIFIED DIMENSIONS IN mm [INCHES] TOLERANCES ON:

2 PLC DEC ± 0.20 [.008]
 3 PLC DEC ± -
 ANGLES ± -

MATERIAL
 COPPER PER ASTM B-152 ANNEALED

FINISH
 SEE TABLE

DR 1/14/94 DK SCHRUM
 CHK 1/19/94 AJ KAUFMAN
 APPD 1/19/94 RE ROSER
 APPD 1/19/94 JL MECKLEY
 PRODUCT SPEC -
 APPLICATION SPEC -
 WEIGHT -

AMP AMP Incorporated
 Harrisburg, PA 17105-3608

NAME
TERMINAL, RING TONGUE, SOLISTRAND™

SIZE **C** CAGE CODE 00779 DRAWING NO **C-36923**
 SCALE 2:1 SHEET 1 OF 1